

Cycle 1, Week 5 – Japanese Pagoda

Ages 7-9

Materials:

- Drawing paper
- Rulers (1 per student and 1 for tutor)
- Pencils
- White board and marker
- Colored pencils
- Images of Japanese prints showing perspective (see links in blog post)

1. Show students images of Japanese art. Have them find and describe the use of one-point perspective. Where does it look like lines are converging? Do the things get smaller or bigger in the distance? How does the use of one-point perspective change how the artwork looks or feels to the viewer?

2. Lead students step by step through drawing the pagoda (see page 2 of lesson plan).

Note: On the step-by-step instructions, there is also a simpler option for creating a single-story building.

3. Once the basic pagoda is finished, students can add details and a landscape.

4. If time, use colored pencils to complete the artwork.



Horizon Line



Vanishing point

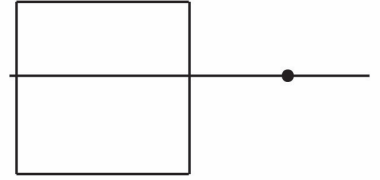

3" x 3" square

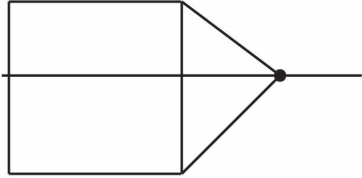

Connect corners to vanishing point

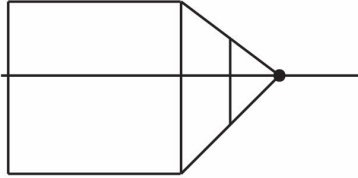

Vertical line to create receding side

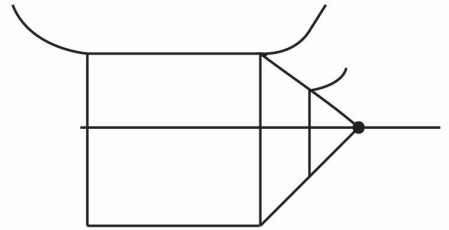

Curved lines at corners (use a smaller curved line at back right corner)

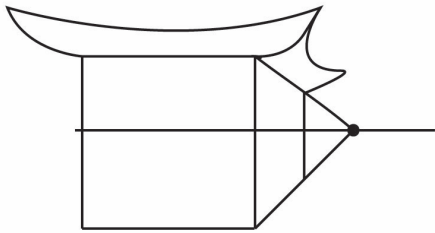

Use curved lines to connect corners
NOTE: you can skip the next 3 steps and just add curved roof lines for a simpler drawing

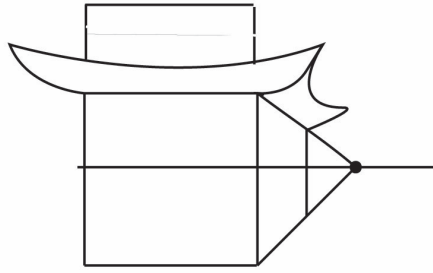

Short rectangle above roof line

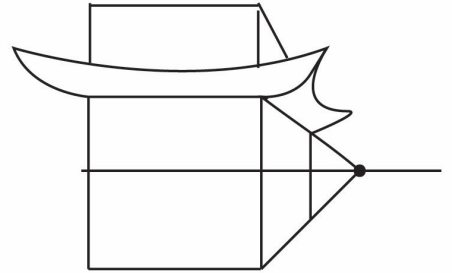

Line angled from corner down to vanishing point

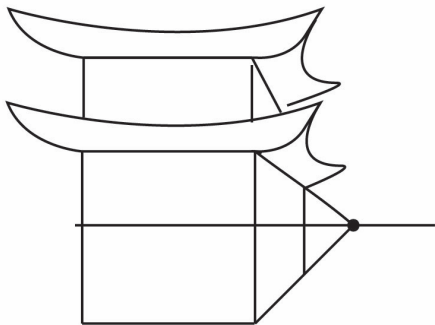

Repeat curved lines at corners. Use curved line to connect across.

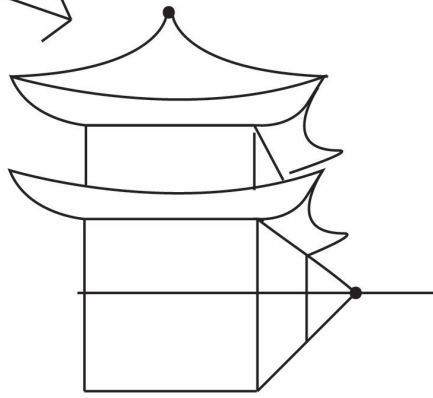

Draw a dot above the center. Draw curved lines from dot to corners

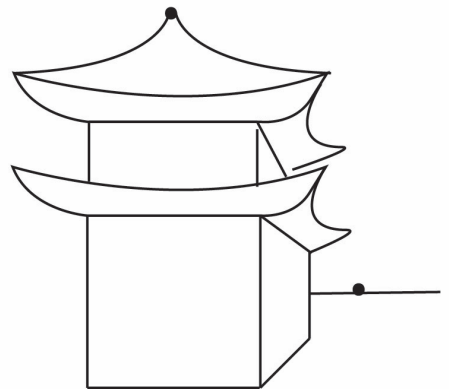

Erase horizon line behind building and lines to vanishing point